

Seal For Targa Roof Sliding Cover Has Been Modified

Vehicle Type: **911 Targa (996)**

Model Year: **As of 2002**

Concern: **The seal of Targa sliding cover crackles/grates with sliding cover closed.**

Information: The seal of the sliding cover is located on the sliding cover frame. If the sliding cover is closed, the seal can cause crackling or grating noises in the area of the contact surfaces of the seal on the Targa roof module.

In order to prevent noises from occurring, a modified seal has been installed with an optimized seal profile in vehicles as of the date of introduction. In the event of a customer complaint, the existing seal on the sliding cover frame should be replaced with the modified seal on vehicles produced before the date of introduction.

Introduction: December 3, 2004, as of the following VIN:

99 95S 63 5085

Parts Information:	Part Number	Description
	996.562.455.01	New/seal
	996.562.455.00	Previous, Seal
	000.043.157.00	Cleaning agent

Work Procedure: **1. Remove existing seal of sliding cover.**

1.1 Remove sliding cover, see Workshop Manual, 911 Targa (996), Group 6, 60 40 19 - Removing and installing lid for sunroof - Targa.



The sliding cover may be damaged if stored incorrectly – Improper storage can damage and scratch the sliding cover.

> Set removed sliding cover on a soft, clean, and slip-resistant surface.

Work Procedure:
(cont'd)

- 1.2 Remove sliding cover frame, see Workshop Manual, 911 Targa (996), Group 6, 60 28 19 - Removing and installing lid frame for sunroof - Targa. When you do this, unclip the water drain hoses (Figure 1, Item C) of the seal from the bracket on the roof assembly.
- 1.3 Pull out seal (Figure 1, Item A) upward all the way around and out of the groove in the sliding cover frame (Figure 1, Item B).
- 2. **Install new modified seal.**

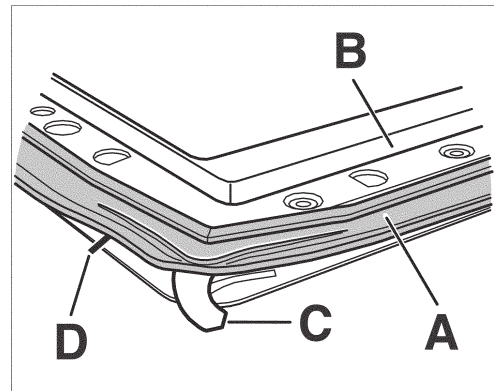

Figure 1



Important!

The seal is secured on the sliding cover frame with adhesive strips on the corners.

- 2.1 Clean bonding surfaces on the corners of the sliding cover frame with cleaning agent.
- 2.2 Press in the new seal, part number, 996.562.455.01, all the way around in the sliding cover frame groove.
- 2.3 Pull off protective film (Figure 1, Item D) from the adhesive strips on the underside of the new seal and press the corners of the seal firmly on the sliding cover frame.
- 2.4 Press the seal with a plastic roller all the way around on the sliding cover frame.
- 2.5 Install sliding cover frame and clip in the water drain hoses of the seal in the bracket on the roof assembly.
- 2.6 Install sliding cover.

Working Time:

Labor Operation	Description	Time Units
60 28 19 40	Rubber seal for sunroof removed and installed This includes: Lid for sunroof removed and installed, frame for sunroof removed and installed	240 TU

Reference:

- POSES, Workshop Manual, 911 Targa (996):
 - > Group 6: 60 28 19 - Removing and installing lid frame for sunroof - Targa
 - 60 40 19 - Removing and installing lid for sunroof - Targa

Important Notice: Porsche Cars N.A Technical Bulletins are intended for use by professional technicians, not a "Do-it-yourselfer." They are written to inform these technicians of conditions that may occur on some vehicles, or to provide information that could assist in the proper service of a vehicle. Special tools may be required to perform certain operations identified in these bulletins. Use of tools and procedures other than those recommended in these bulletins may be detrimental to the safe operation of your vehicle. Properly trained technicians have the equipment, tools, safety instructions and know-how to do a job properly and safely. If a condition is described, do not assume that the bulletin applies to your vehicle, or that your vehicle will have that condition. See your Porsche Dealer for information on whether your vehicle may benefit from the information. Part numbers listed in these bulletins are for reference only. Always check with your authorized Porsche dealer to verify correct part numbers.

©2005 Porsche Cars North America, Inc.

Dealership	Service Manager	_____	Shop Foreman	_____	Service Technician	_____	_____	_____	_____
Distribution	Asst. Manager	_____	Warranty Admin.	_____	Service Technician	_____	_____	_____	_____
Routing									

Dr. Ing. h.c. F. Porsche AG is the owner of numerous trademarks, both registered and unregistered, including without limitation the Porsche Crest®, Porsche®, Boxster®, Carrera®, Cayenne®, Tiptronic®, VarioCam®, PCM®, 911®, 4S®, and the model numbers and distinctive shapes of Porsche's automobiles such as, the federally registered 911 automobile. The third party trademarks contained herein are the properties of their respective owners. Porsche Cars North America, Inc., believes the specifications to be correct at the time of printing. However, specifications, standard equipment and options are subject to change without notice. Printed in the USA